

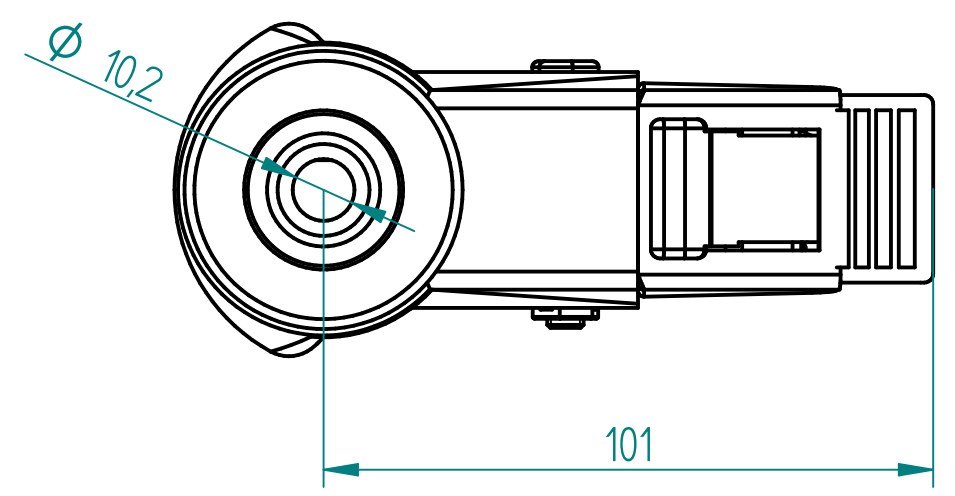

SECTION A-A

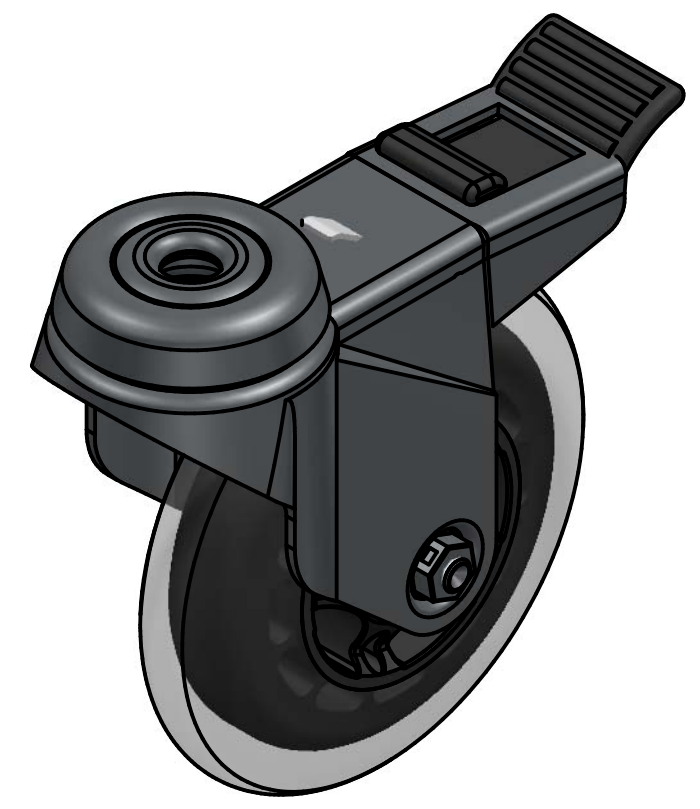
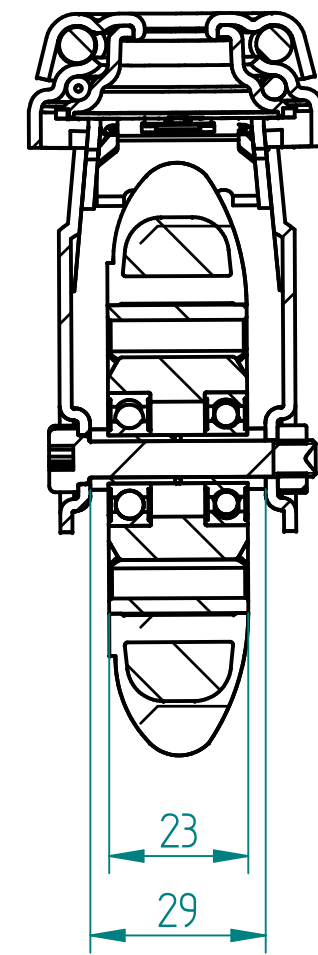

Load Capacity : 50Kg, for speed up to 4Km/h  
(according to EN12530:1998)

	PRODUCTION OF INSTITUTIONAL CASTORS AND WHEELS		PERMIS. VARIATIONS:	PART No:	
	THESSALONIKI - GREECE		SURFACE FINISH:	UNF. DIM.:	
This drawing is the property of RODA S.A. It must neither be reproduced in any manner nor shall it be submitted to third parties or competitors without our written consent			DESIGNED	13/7/2021	ALISANDRATOS S.
			DRAWN	13/7/2021	ALISANDRATOS S.
			CHECKED	13/7/2021	SAATSOGLOU H.
			MATERIAL : Swivel castor with brake, steel support, bolt hole Ø10mm. Wheel 98x23mm, non marking PU (85ShA), ball bearing.		PART DESCRIPTION : <b>M100PUSHSBK</b>
C3			QUANTITY	SCALE	DRAWING
B2			REPLACE		SHEET No.
A1					GEN. DWG. NUM. :
A/A					